

# HK526E

## ENCODER/DECODER IC

## ENCODER WITH 4096 SET CODE

### Features

- \* A pair with HK526A ( Decoder ) for remote controller IC
- \*  $2^{12} = 4,096$  binary codes
- \* 4 word transmission cycle each time
- \* DIP 18 or SOP 20 be available

- \* With HK526B and HK526C for wireless control door bell IC
- \* With HK526D for wireless control touch dimmer IC
- \* HK526E Rosc be about  $1.1M\Omega$  for HK526B , HK526C and HK526D

### General Description

The HK526E is a CMOS ASIC encoder. It will en-code 12 parallel data inputs ( A0 ~ A11 ) and serially transmit them to the output when transmitter enable pin be depressed ( TE pin contacted to low ) . The address inputs are 2 states , i.e. low ( 0 ) or open ( 1 ) . It will transmit 4 cycles each time when TE pin depressed.

### Application

- \* Car/home alarm system
- \* Garage control
- \* Wireless door bell
- \* Wireless light control etc...

### PinOut Diagram

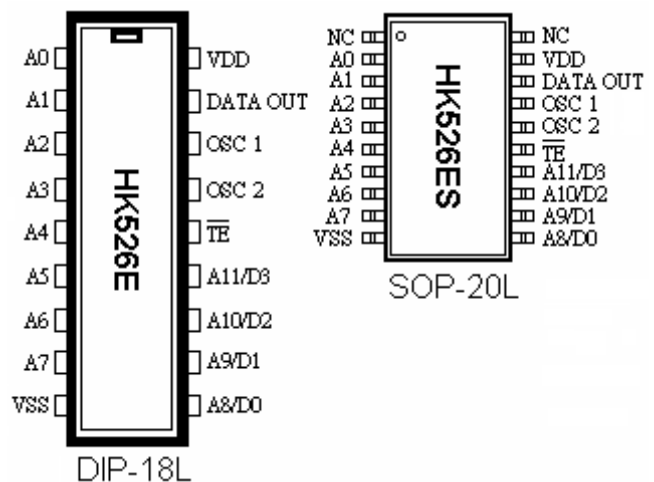

### Pin Assignment

PIN NAME	PIN NO( DIP form )	PIN NO ( SOP form )	DESCRIPTION
A0	1	2	Address inputs
A1	2	3	Address inputs
A2	3	4	Address inputs
A3	4	5	Address inputs
A4	5	6	Address inputs
A5	6	7	Address inputs
A6	7	8	Address inputs
A7	8	9	Address inputs
VSS	9	10	Negative power supply
A8 / D0	10	11	Address / Data inputs
A9 / D1	11	12	Address / Data inputs
A10 / D2	12	13	Address / Data inputs
A11 / D3	13	14	Address / Data inputs
TE	14	15	Transmit enable
OSC2	15	16	Oscillator output
OSC1	16	17	Oscillator input
Dout	17	18	Serial output of encoded signals.
VDD	18	19	Positive power supply
NC	X	1	No Connecting
NC	X	20	No Connecting

# HK526E

## ENCODER/DECODER IC

## ENCODER WITH 4096 SET CODE

### Block Diagram

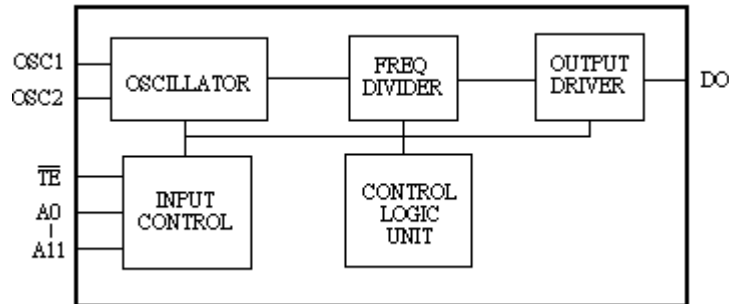

### Timing Waveform

#### Bit Format

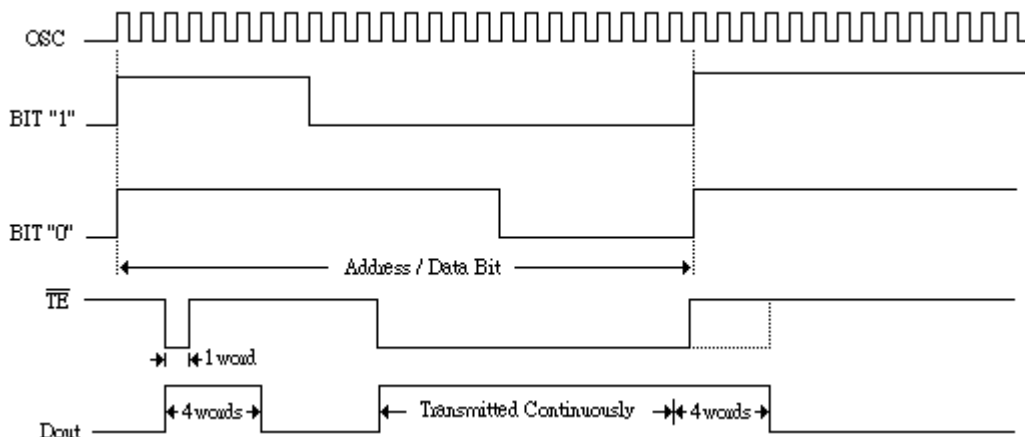

HK526E begin a 4 word transmission cycle upon receipt of a transmission enable ( TE pin active Low ) . This cycle will repeat itself as long as the transmission enable ( TE pin held Low ) . Once the transmission enable returns high the encoder output completes its final cycle and then stops shown below

# HK526E

## ENCODER/DECODER IC

## ENCODER WITH 4096 SET CODE

### Operating Flowchart

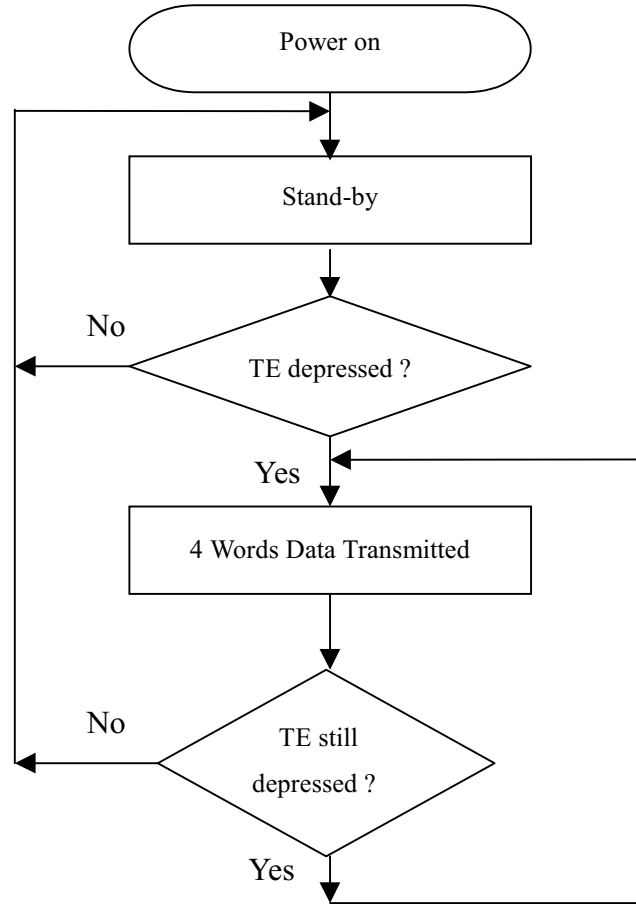

### Oscillator Frequency

Encoder OSC frequency

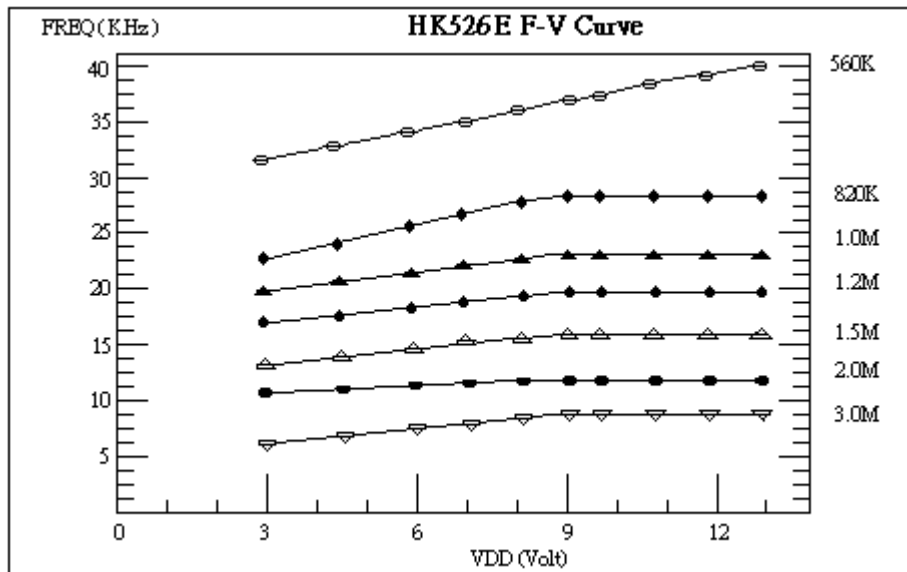

# HK526E

## ENCODER/DECODER IC

## ENCODER WITH 4096 SET CODE

The recommended oscillator frequency about  $F_{oscE}$  (HK526E)  $\cong F_{oscD}$  (HK526A) / 10

Recommended oscillator resistor (  $R_{osc}$  ) for HK526E , HK562A , HK562B / HK562C / HK562D

HK526E ( $R_{osc}$ )	HK526A ( $R_{osc}$ )	HK 526B ( $R_{osc}$ ) HK526D ( $R_{osc}$ )
820K $\Omega$	47K $\Omega$	****
1.1M $\Omega$	68K $\Omega$	220K $\Omega$
1.5M $\Omega$	100K $\Omega$	****
2M $\Omega$	150K $\Omega$	****
3M $\Omega$	180K $\Omega$	****

VDD = 9 V ~ 12 V

### Maximum Rating ( $T_A = 25^\circ\text{C}$ )

Parameter	Rating	Unit
Supply Voltage	-0.3 ~ 13	V
Input Voltage	VSS - 0.2 ~ VDD + 0.2	V
Operation Voltage	VSS - 0.2 ~ VDD + 0.2	V
Maximum Power Dissipation	500	mW
Operating Temperature	-20 ~ 75	$^\circ\text{C}$
Storage Temperature	-50 ~ 125	$^\circ\text{C}$

### Electrical DC Characteristics

Parameter	Symbol	Conditions	Min	Typ	Max	Unit
Operating Voltage	VDD		3	-	12	V
Supply Current	ISS	VDD=12V OSC stop A0 – A11 open	-	0.02	0.3	mA
Stand by Current	ISB	Oscillator stop VDD= 3V Oscillator stop VDD= 12V	-	0.1 2	1 4	mA
Operation Current	IDD	No load VDD = 3V Fosc=3KHz VDD = 12	-	40 150	80 300	mA

# HK526E

ENCODER/DECODER IC

ENCODER WITH 4096 SET CODE

## Application Diagram

